

The Beghelli water machine:
 Preview reserved to our European customers



Suggested retail price
 290 €

Beghelli

www.beghelli.com
 BEGHELLI SpA - Via Mazzepine, 13/15 - 40050 Montevoglio (BO) - Italy - Tel. +39 051 960411 - Fax +39 051 960444

This message is confidential and intended for distributors of Beghelli Group only. Trade marks, commercial information and technical characteristics of the product named "Macchine self service Beghelli" are hereby indicated and copyright before product launch in the market. Beghelli reserves the right to modify the product without prior notice without this responsibility to be at the end of Beghelli.



line
STELLAPOLARE
 THE LEADING EMERGENCY LIGHTING FIXTURES **LED**

LOGICA LED SPECIAL OFFER
 2011-2012



**A BEGHELLI PROMOTION
 FOR CRYSTAL WATER**



Beghelli

**Purchase the Promotional Qbox
 with 10 Logica Led
 and you will receive the new
 Beghelli Water Machine**



Qbox – 10 Logica Led + Beghelli Water Machine

Included:
 5 Logica Led 6W SE – Part No.12182
 5 Logica Led 11W SE – Part No.12183
 Water bottle containing a coupon that enables you to get your Beghelli Water Machine

THE BEGHELLI WATER MACHINE: WHY IT IS WORTHWHILE, HOW IT WORKS

SAVINGS ON THE PURCHASE OF MINERAL WATER
(for a family, a standard of 350-400 € per year) *

REDUCTION OF THE ENVIRONMENTAL COST RELATED TO THE MANUFACTURING AND TRANSPORTATION OF WATER PLASTIC BOTTLES
AVOID BUYING AND MOVING WATER BOTTLES

GENERAL CHARACTERISTICS

- Electronically monitored double technology and double time filtering system (up to 6 months and maximum 1,000 liters)
- High filtering speed up to 1 liter per minute
- Capability to make sparkling water (up to 60 liters)
- Depending on the available tap water, the Beghelli Water Machine offers several settings of the water filtering
- Self-diagnostic of the filtering and cleaning system with multicolored led which signals:
 - the amount of water dispensed
 - the amount of sparkling the water
 - the status of the filter
 - the status of the sparkling filter
 - the status of the sterilizing light beam
- No need to connect to the water faucet
- Possibility to be unconnected to the mains via battery system with up to 20 days of autonomy
- Self contained pitcher for water filling up to 1.8 liters
- In conformity with European standards

PROVIDED ACCESSORIES

- Glass bottles, 2 filters, 2 plastic bottles, CO2 tank for sparkling water production



DOUBLE TECHNOLOGY FILTERING SYSTEM

- Double filtering with a 4 stages cartridge and disinfecting Inox UC-C function

The Beghelli Water Machine offer a 99.9% bacteria coverage with the reduction of organic and inorganic (solvents, pesticides, chlorine, zinc, copper, arsenic, limestone, heavy metals, etc.) elements.

* yearly evaluation based on daily consumption of three bottles of water at 0.30 € each

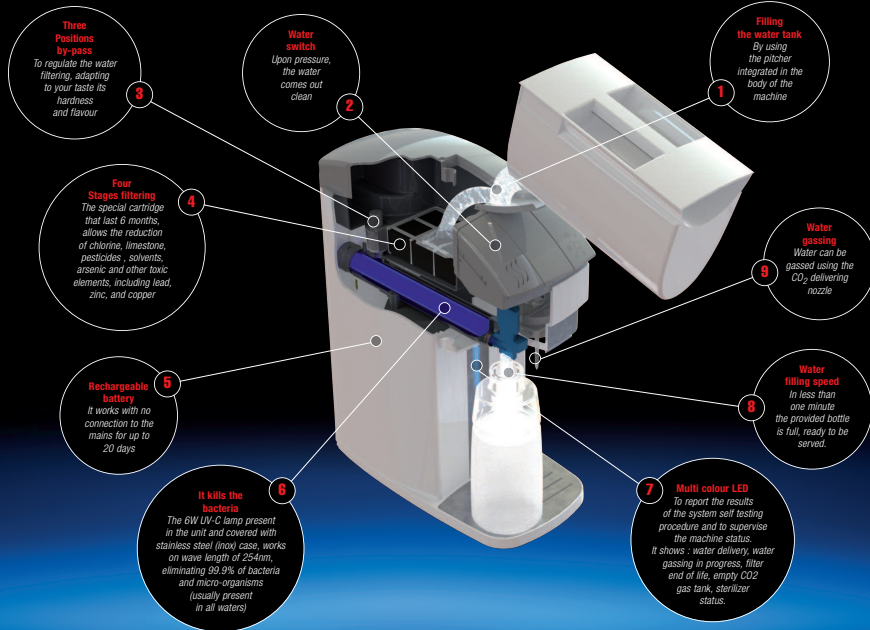

3 Three Positions by-pass
To regulate the water filtering, adapting to your taste its hardness and flavour

2 Water switch
Upon pressure, the water comes out clean

1 Filling the water tank
By using the pitcher integrated in the body of the machine

4 Four Stages filtering
The special cartridge that last 6 months, allows the reduction of chlorine, limestone, pesticides, solvents, arsenic and other toxic elements, including lead, zinc, and copper

5 Rechargeable battery
It works with no connection to the mains for up to 20 days

8 It kills the bacteria
The UV-UV-C lamp present in the unit and covered with stainless steel (inox) case, works on wave length of 254nm, eliminating 99.9% of bacteria and micro-organisms (usually present in all waters)

7 Multi colour LED
To report the results of the system self testing procedure and to supervise the machine status. It shows: water delivery, water gassing in progress, filter end of life, empty CO2 gas tank, sterilizer status.

9 Water gassing
Water can be gassed using the CO2 delivering nozzle.

6 Water filling speed
In less than one minute the provided bottle is full, ready to be served.

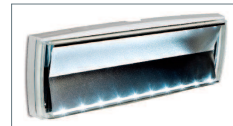

GENERAL SPECIFICATIONS

Power: 8, 11, 24 W
Operation: Non-maintained (SE), Maintained or Public Venues (SAPS)
Conformity: EN 60598-1, EN 60598-2-2, EN 60598-2-22, UNI EN 1838, UNI 11222
Grado di protezione: IP55
Duration: 1h, 2h, 3h (may be set using the DIP switch)
Mounting: Wall, ceiling, recessed false ceiling
Housing: PA6, 7035 grey polycarbonate
Optic: Symmetrical, in anodized aluminum

PRODUCT HIGHLIGHTS

- High luminous efficiency thanks to 30 power LEDs (up to 600 lm)
- Modern and rational design
- The quick-fit bracket mounting allows great installation and maintenance speed
- A single lighting fixture can illuminate areas up to 300 sqm and covers up to 10 mt of walking distance in escape routes
- The luminous flux distribution follows a non-conventional pattern that works at the same time on two crossing planes, thus realizing a highly performing photometric solid on all types of installations.

LT	Ordering code (series)	Dimension	Flux (lm)	Power	Quality
1	12162	68	150/30	400/200/150	3/1W
2	12166	SAPS	150/30	400/200/150	3/1W
11	12163	68	150/30	400/200/150	3/1W
11	12166	SAPS	150/30	400/200/150	3/1W
24	12164	96	180/36	500/300/200	3/1W
24	12167	SAPS	150/30	400/200/150	3/1W

FEATURES PARTICIPATING TO THE "BEGHELLI WATER MACHINE" PROMOTION

12175 - Logica PFC Right screen - to be ordered separately
12176 - Logica PFC Left screen - to be ordered separately
12177 - Logica PFC Down screen - to be ordered separately

WALL MOUNTING WITH QUICK-FIT BRACKET AND BUBBLE LEVEL



12109 Bracket for quick-fit mounting - supplied

The Logica LED range

Professional LED emergency lighting

This emergency luminaire features an extremely sophisticated electronic technology. The Logica LED is the only emergency luminaire supplied as a centralised version (L.G, L.GFM), with the Autotest (AT) version automatically configuring if it is not connected to a control unit. Individual luminaires can also be manually tested, using a magnet with the magnetic switch below the screen.

This technology makes it possible to immediately test luminaire efficiency. The circuit also allows for the fixture to be customised to requirements. Duration can be adjusted, (1h/2h/3h) and Maintained versions can be changed to Public venue versions, adjusting light intensity to the venue requirements.

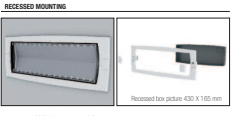

12198 Logica PFC recessed BCK - supplied



12175 Logica PFC Right screen - to be ordered separately
12176 Logica PFC Left screen - to be ordered separately
12177 Logica PFC Down screen - to be ordered separately

FALSE CEILING AND PLASTERBOARD MOUNTING



12193 Logica false ceiling bracket - to be ordered separately